



## DATASHEET & USER GUIDE

### XLED-PS8-RDM

## SCOPE OF SUPPLY

Check completeness of supplied device immediately after receipt.

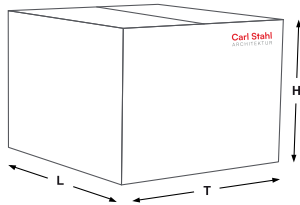

**1** XLED-PS8-RDM

**2** Datasheet & User Guide

**3** (If required) IP65 protection for RJ45 cable

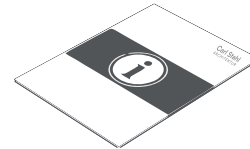

## TRANSPORT AND SHIPPING

Our products are shipped in the following formats – Keep dry and protect from damage!

### XLED-PS8-RDM

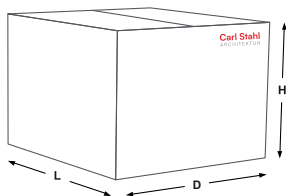

(1x XLED-PS-8)

**Individual box**

Weight: max. 6,00 kgs  
Dimensions (L x D x H) 480 x 200 x 150 mm  
18.90" x 7.88" x 5.91"

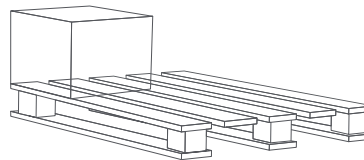

**Euro pallet (Standard 800 x 1200 mm)**

Pallet weight: 50 to 350 kgs  
Pallet height: 400 to 1000 mm  
15.75" to 39.37"

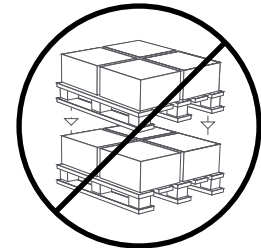

**Euro pallet / Shipment**

## PRODUCT SPECIFICATIONS

The **XLED-PS8-RDM** is a digital driver designed to control both P-Type and A-Type XLED-DOTs / XLED-LINEs, providing seamless operation across various sizes, forms, and color configurations. It features two internal power supplies to ensure optimal performance and reliability.

### **Advanced Integration & Performance:**

Equipped with an integrated MADRIX Stella board, the **XLED-PS8-RDM** combines unparalleled performance and adaptability, offering maximum flexibility for system designers and integrators.

### **Protection & Self-Diagnostics:**

Comprehensive Protection: All inputs and outputs are safeguarded against overload and surge conditions.

Built-in Self-Testing Feature:

- This function, accessible via custom RDM PIDs, enables LED line integrity and performance testing.
- It can be executed as a "pre-show routine" or an "on-demand off-show test" to detect potential anomalies at both the LED line and DOT level.

### **Real-Time Monitoring & Smart Alerts:**

By utilizing multiple internal sensors, including:

- Main board temperature sensors
- Output voltage & current probes

The system can deliver real-time monitoring data and can be configured to trigger notifications, warnings, or alarms, where applicable.

### **RDM Control & Firmware Management:**

The bi-directional digital data communication system enables, LED intensity control via the RDM protocol. This allows monitoring of critical driver parameters, such as: Output voltage & current, Addressing information, Lifespan data, etc.

Firmware updates can be uploaded and downloaded using a specialized device.

### **Addressing Options:**

The LED-DOTs / LED-LINEs can be addressed through:

- RDM software (digital addressing)
- Internal DIP switches (hardware-based addressing)

*The MADRIX STELLA is a dedicated control interface for DMX512 and Art-Net or Streaming ACN that is designed for high quality and practicability in permanent LED installations.*

### **Art-Net / Streaming ACN / USB:**

Art-Net or Streaming ACN data is directly converted to DMX512. Optimize and decentralize cabling to cover any distance to the device using Ethernet network.

### **2 DMX-IN/OUT:**

Up to 1024 DMX channels (2 DMX universes), can be controlled by Art-Net or sACN protocols.

### **Sync Mode:**

MADRIX 5 and MADRIX hardware allow you to fully synchronize Art-Net data for all output ports and across multiple devices to get an optimal image on the LEDs without visual interruptions.

### **3rd-Party Controllers:**

MADRIX STELLA complies with official protocol specifications and can be used as a regular node with your other consoles, controllers, or software solutions.

### **Daisy-Chain Support:**

2 Ethernet ports allow for separate network connections as well as linearly daisy-chaining several devices together.

PRODUCT VIEW



### INPUT

AC Voltage range	100-240 VAC $\pm 10\%$		
DC Voltage range	141-340 VDC $\pm 10\%$		
Power consumption @Pout=max.W	440W	435W	640W
Input current @ 115VAC	3.8A	3.8A	5.6A
Input current @ 230VAC	1.9A	1.9A	2.8A
Frequency	50-60Hz		
Power Factor (Typ.)	PF $\geq 0.98$ @ 115VAC or PF $\geq 0.94$ @ 230VAC		
Efficiency (Typ.)	94%		
Inrush current (Typ.) <sup>1</sup>	60A @ 115VAC or 120A @230VAC (Cold start)		
Leakage current	<1.5mA @ 240VAC		

Note 1: Tolerance  $\pm 10\%$

### OUTPUT

DC Voltage (Typ.)	12VDC	15VDC	24VDC
DC Voltage adj. range <sup>1</sup>	11.4VDC - 12.6VDC	14.3VDC - 15.8VDC	22.8VDC - 25.2VDC
Max. current (Outputs 1-4)	16.7A	13.5A	12.5A
Max. current (Outputs 5-8)	16.7A	13.5A	12.5A
Continuous max. system power <sup>2</sup>	400W	400W	600W
Output channels	4+4 (2 groups)		
Max. no. of DOTs (3 Outputs config) <sup>3</sup>	56 RGB - 42 RGBW		
Max. no. of DOTs (4 Outputs config) <sup>3</sup>	42 RGB - 32 RGBW		

Note 1: Voltage Tolerance  $\pm 1\%$

Note 2: Max. power is considered in static use at full intensity, full white and Ta=25°C (77°F). Please check the derating curve for more details (Graph 1).

Note 3: It is recommended to distribute the load equally on all the outputs. It is also suggested to evaluate the voltage drop of each line to ensure the min. acceptable voltage on the last DOT.

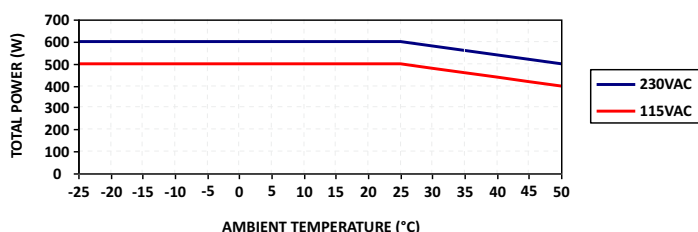

Graph 1: Derating curve

## CONTROL AND SETTING

Input control protocols	Art-net or sACN
Protocol detection	Automatic
RDM Compliance (over Art-Net)	ANSI/ESTA E1.20
Art-Net Compliance	Art-Net 1, 2, 3, 4 incl. ArtSync
sACN Compliance	ANSI E1.31
Ethernet	10/100 MBit/s (Compatible with 1 GBit/s)
USB	USB 2.0
Output control	2x DMX512A (2x Universes - 1024 Channels)
Firmware update	Yes (with special XLED device)

## CONNECTIONS

Power input	2x M20x1.5 cable glands
Ethernet	2x RJ45 waterproof connectors
USB	A-Type female waterproof connector
Output	8x 5pin IP66 connectors
Output cable section range	0.25mm <sup>2</sup> - 1.5mm <sup>2</sup> (24AWG - 15AWG)

## PROTECTIONS

Overtemperature	Yes (only with RDM feedback)
Output short circuit	Yes (only on hot wires)
Overload	10A fuses (each output)

## MEASURES (by RDM)

Board temperature	Yes (both internal PCB)
Output voltage	Yes (each output)
Output current	Yes (each output)
Operational time (XLED-PS8-RDM)	Yes (both internal PCB)
Operational time (XLED-LINEs)	Yes (each output)

## THERMAL

Ambient temperature <sup>1</sup>	-25°C - +50°C (-13°F - +122°F)
Operating temperature (Inside PS8-RDM housing) <sup>1</sup>	-10°C - +70°C (14°F - +158°F)
Storage temperature	-40°C - +70°C (-40°F - +158°F)
Case temperature	max. 70°C (max. 158°F)
Humidity	10-90% (non-condensing)
Cooling	Convention

## OTHERS

Dimensions (LxHxW) <sup>2</sup>	382mm (426mm) x 131mm x 184mm 15.039" (16.77") x 5.158" x 7.244"
Weight (kgs)	4.4
Environment	Outdoor, IP65
Housing color	Grey RAL7044 or black matt RAL9005 (other colors on request)
Housing	Aluminium
Installation orientation (Indoor)	Any
Installation orientation (Outdoor)	Horizontal
Surface mounting	4x M6 mounting holes

Tolerances: (1) Max. power is considered in static use at full intensity, full white and Ta=25°C (77°F). Please check the derating curve for more details (Graph 1).  
Remarks: (2) according to ISO 2768-1m

### DIMENSIONS

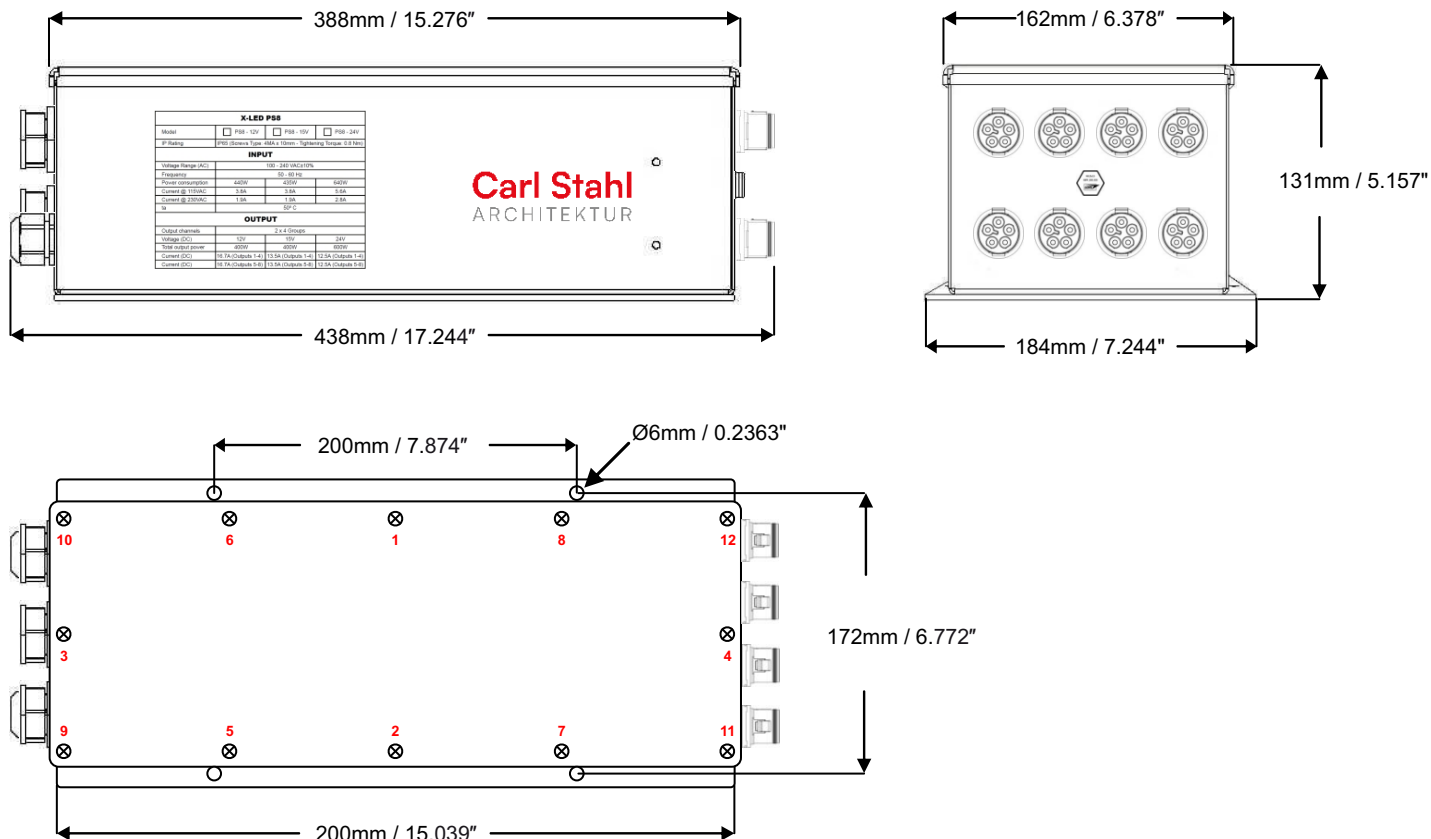

### OPENING AND RE-CLOSING INSTRUCTIONS

To preserve the IP65 rating of the system, **opening and re-closing the device should be avoided whenever possible**, as it may compromise or damage the equipment.

However, if opening the system is absolutely necessary, please follow these **strict guidelines**:

- The operation must be carried out **only by qualified personnel**.
- If a screw is lost or needs replacement, use only identical screws to the originals: Type: **M4 x 10mm (stainless steel ISO 7045)**
- Threaded insert length: **12mm (max.)**
- Tightening Torque: **0.8Nm (min.) - 1.5Nm (max.)**
- Tightening Sequence & Procedure: To ensure even gasket compression, prevent leaks, and avoid cover warping, follow the specified tightening sequence (refer to drawing above).

1. First pass: Insert all screws by hand.
2. Second pass: Tighten screws to 50% of the final torque.
3. Third pass: Tighten screws to 100% of the final torque.
4. **After tightening, check that all screws are properly secured and that the cover fully closes, with no visible gap remaining**

By carefully following these steps, the integrity of the IP65 protection is maintained, ensuring the device remains fully operational and protected.

## MOUNTING



NOTE: Device must only be mounted in the positions as indicated.

### Indoor

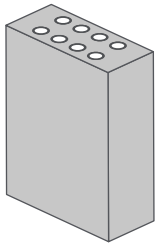

wall mounting  
connectors **any** side

### Outdoor

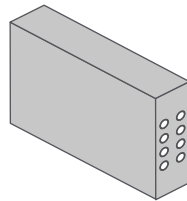

wall mounting  
connectors to the side

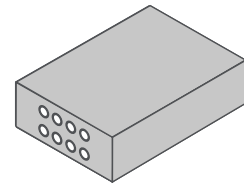

flat position

Connect fixture line, data line and power line according to installation instructions. Device must be used with closed cover only. It is essential to ensure that no stagnant water can accumulate on the power supplies. Power supplies must not be installed or mounted directly beneath water drains or similar sources. When a chain, USB cable, power cable, or RJ45 cable isn't connected, the supplied protective caps must be used and it's important to cover any exposed connectors or passageways properly.



Kindly review the circuit diagram / electrical plan and ensure that it conforms to all essential surge protection requirements. It is advisable to utilize a surge protection device. The warranty does not cover damages resulting from voltage surges

## CONNECTIONS AND LABELING

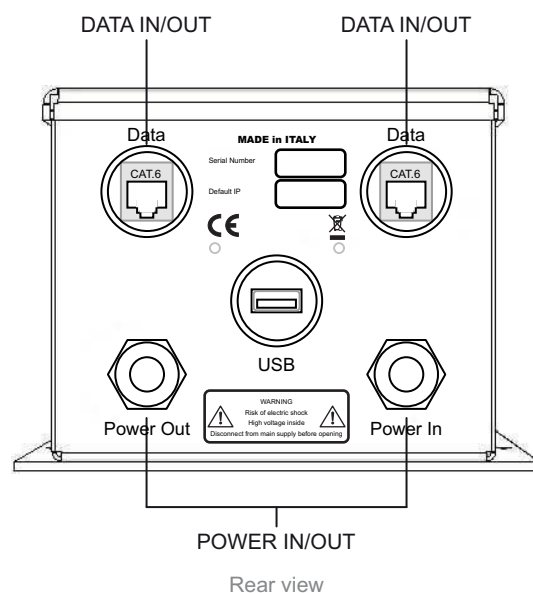
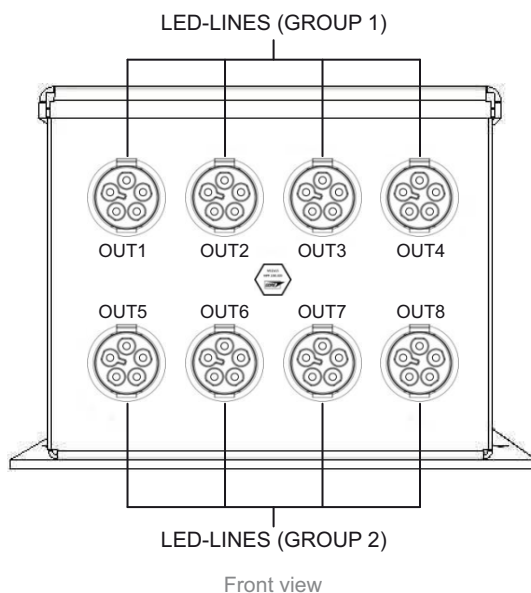

### INTERNAL CONNECTIONS

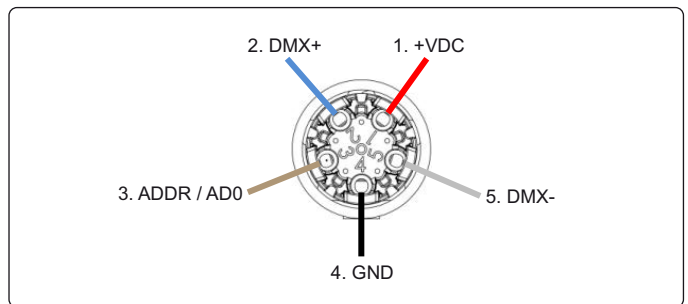
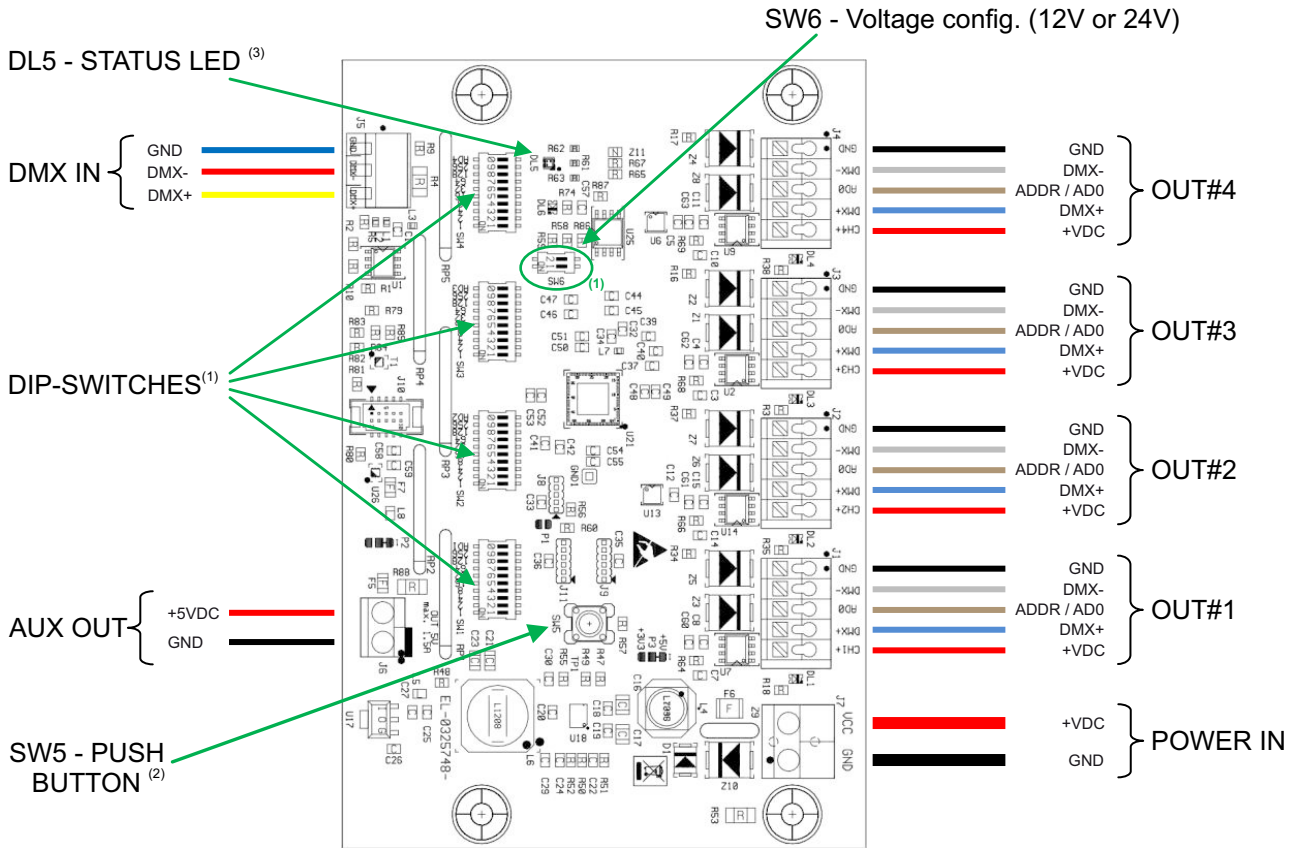

Notes (1): The two embedded PCB splitters each contain four+one DIP switches. Four switches (SW1-SW4) are used to set DMX addresses for the connected LED-DOT Line and select the PCB configuration mode, depending on the type of LED strips used. Additionally, one extra DIP (SW6) switch is provided to select the voltage configuration (12VDC or 24VDC)

Notes (2): The SW5 push button is used to initiate the programming/addressing procedure for the P-Type LED-DOT Lines.

Notes (3): The DL5 Status LED provides visual indications of the system's status:

- Operating mode: GREEN/YELLOW
- DMX RX-signal status: BLINKING/STATIC (DMX present/absent)
- Configuration or settings errors: RED
- P-Type LED-DOT Line programming mode: BLUE

### P-TYPE LED-DOTS / LINES CONNECTIONS

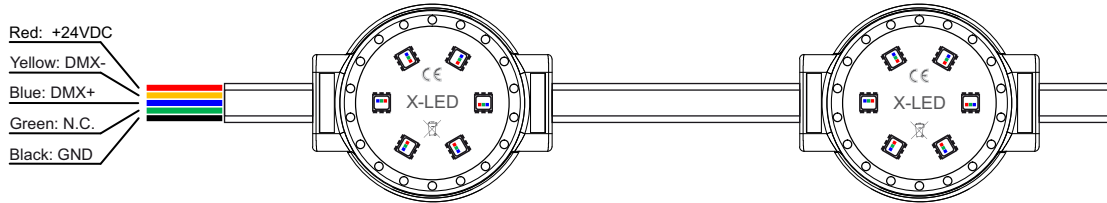

(Pre-)Programmable XLED-DOTS / LINES (RGB(W)) (EL-42G / EL-52G)

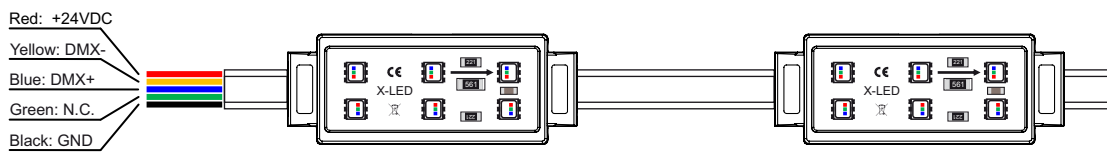

(Pre-)Programmable XLED-DOTS / LINES (RGB(W)) (EL-44X)

The wiring schematics shown above apply when the driver is configured to handle P-Type LED-DOTS (LED-DOTS without automatic addressing)

**Enhanced Mode:** In this mode, DMX addressing can be performed either via RDM or using the "Hardware Procedure".

**XLED Node Mapper:** If P-Type LED-DOTS have been pre-addressed using the XLED Node Mapper, the Enhanced Mode described above is not required.

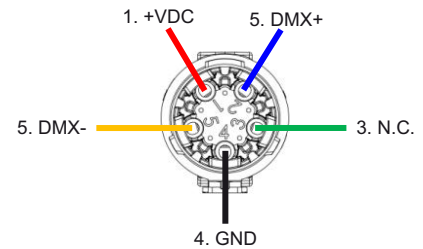

### A-TYPE LED-DOTS / LINES CONNECTIONS

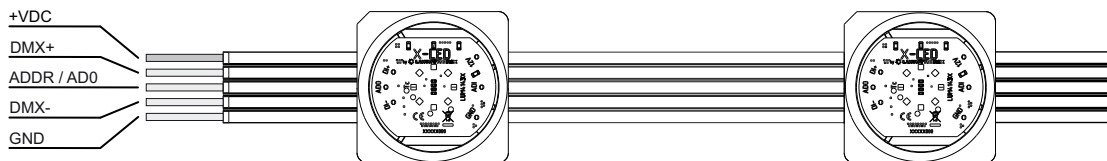

Auto-Addressable XLED-DOTS / LINES (RGB/RGBW)

The above wiring schematic is used when the driver is set to handle LED strips A-Type (LEGACY Mode); DMX initial Addressing is done in this case via the PCB splitter's on-board dip-Switches.

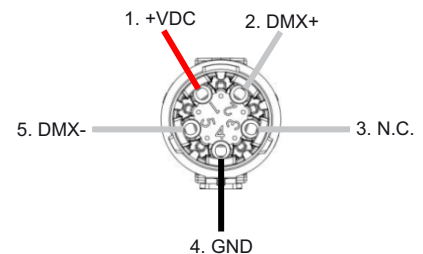

**NETWORK CONNECTION WITH SWITCH OR HUB**

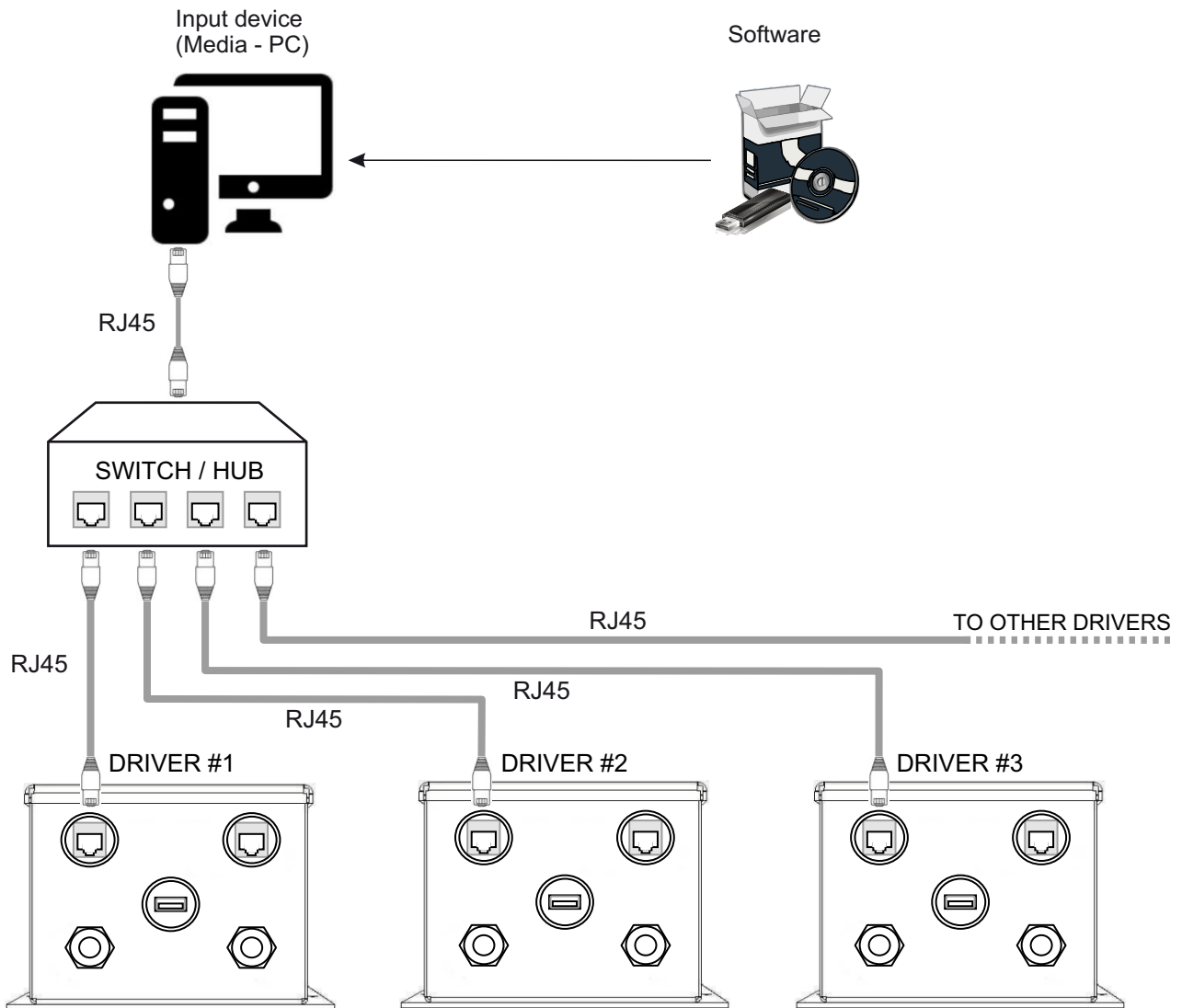

To ensure a flawless and stable data connection, it is recommended to use an RJ45 cable with a minimum specification of CAT 5. The maximum allowable length for an RJ45 cable between SWITCH/HUB and DRIVER, without using an extender, is 100 meters.

## DAISY-CHAIN NETWORK CONNECTION

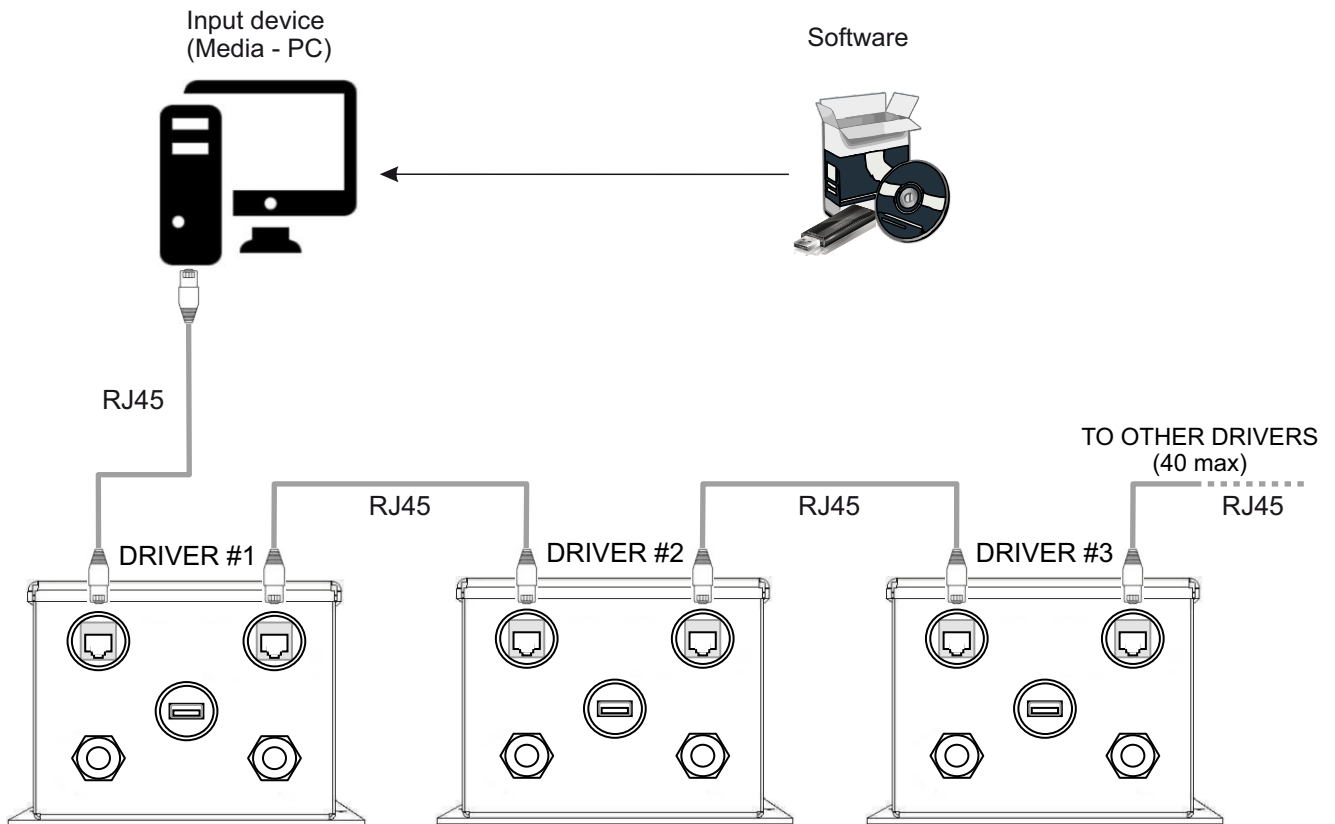

### Daisy-Chain Network connection (40 drivers max)

To ensure a flawless and stable data connection, it is recommended to use an RJ45 cable with a minimum specification of CAT 5. The maximum allowable length for an RJ45 cable between DRIVER and DRIVER, without using an extender, is 100 meters.

## POWER LINE CONNECTION

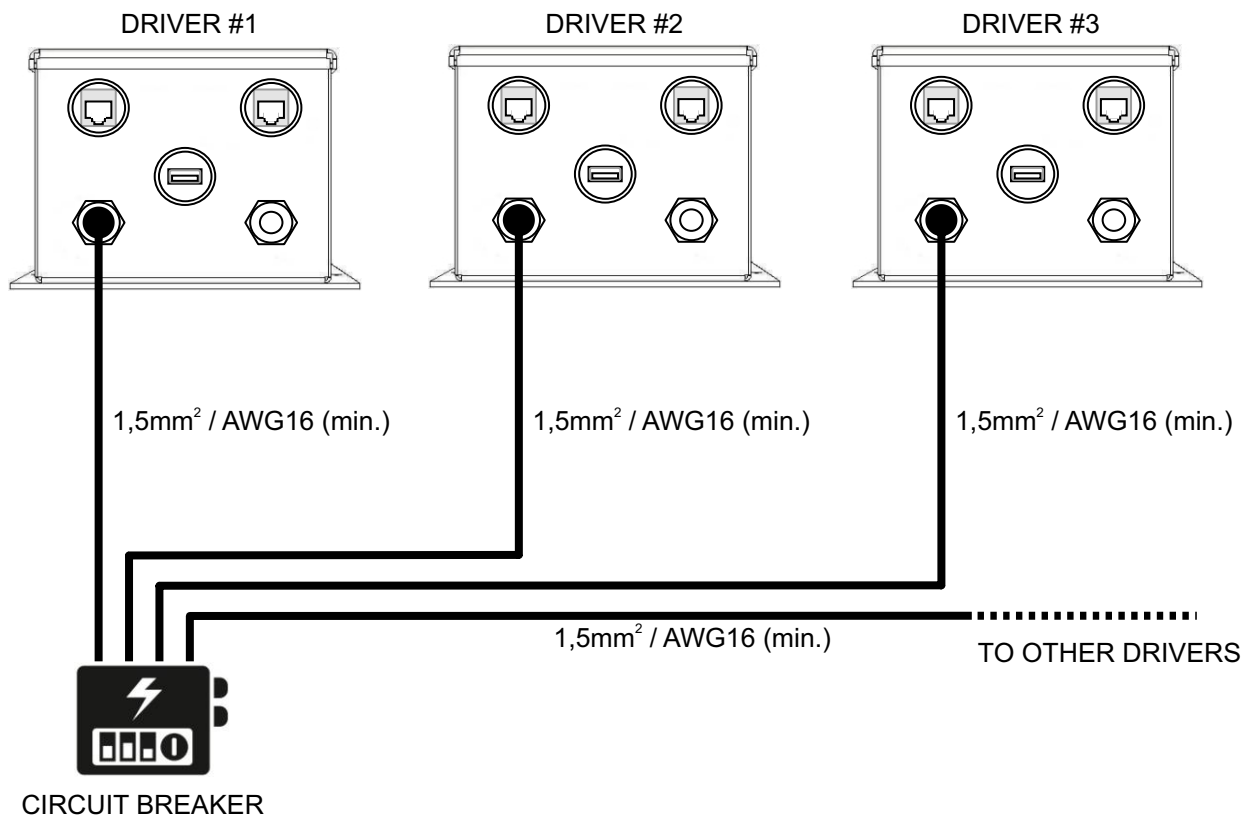

**Please note:** It is mandatory to connect the earth/ground wire(s) to the designated yellow-green terminal block, in accordance with the diagram provided.

All cables equipped with end terminals can be connected directly to the terminal block (TB) by simply inserting them and pressing down until a click is heard – no tools are required for this process. In cases where stranded wires (without end connectors) are used, these must be secured using the terminal block's internal retention springs. For this, a flathead screwdriver is required.

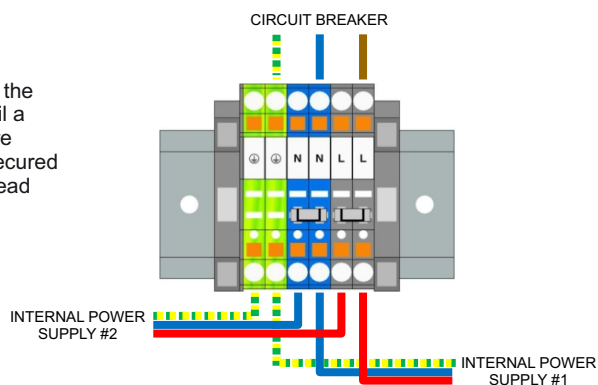

To maintain the product's technical specifications and IP rating, and to ensure compliance with all safety regulations in the country of installation, this product must be installed exclusively by professionally trained personnel.

**POWER LINE CONNECTION (DAISY CHAIN)**

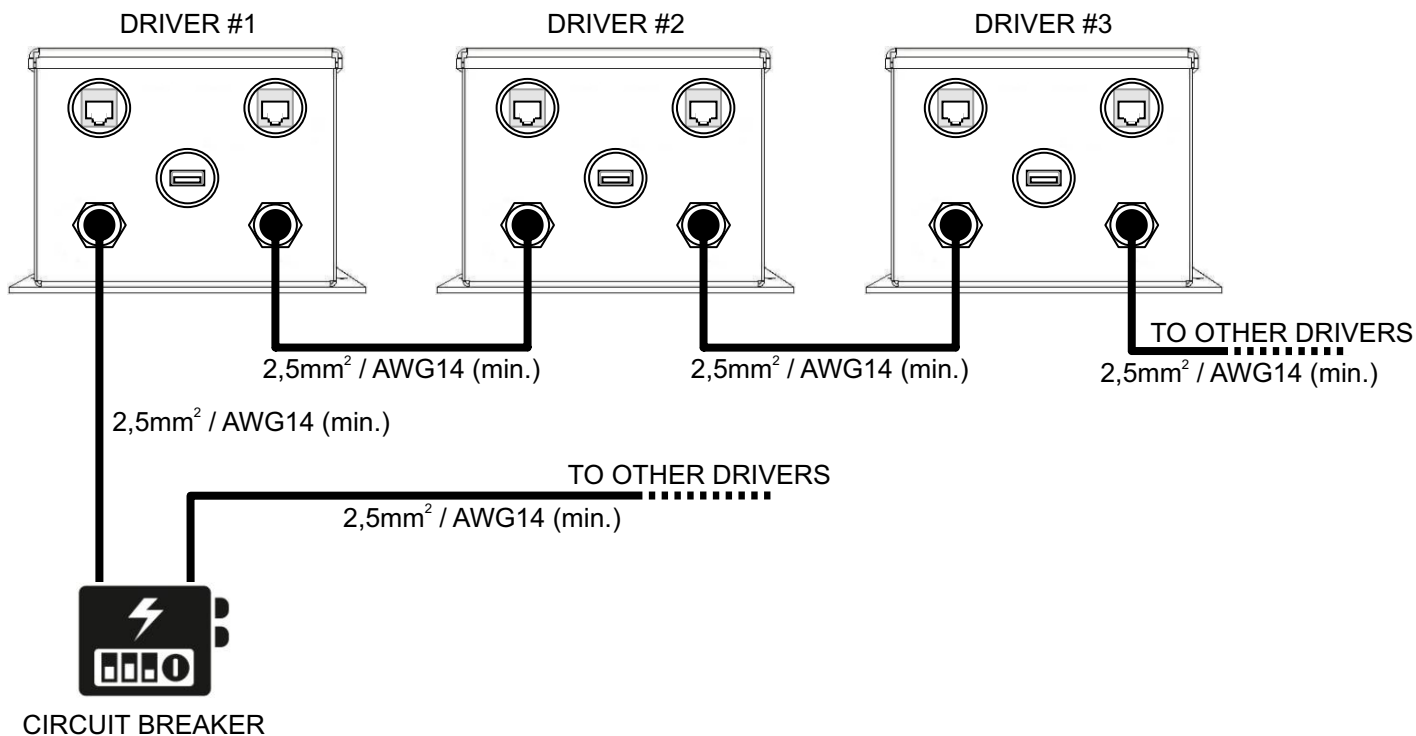

Installation type	Max drivers @ 115VAC	Max drivers @ 230VAC
Open-air cable	5	10
Ducted cable (@25°C)	3	6
Ducted cable (@50°C)	2	4

**Please note:** It is mandatory to connect the earth/ground wire(s) to the designated yellow-green terminal block, in accordance with the diagram provided.

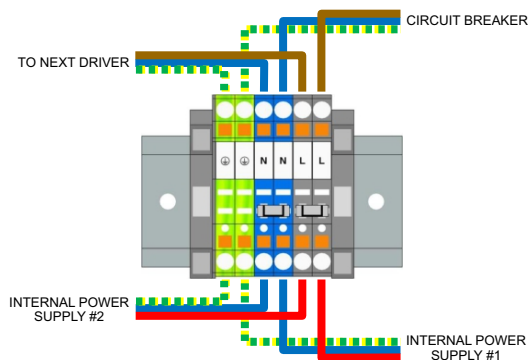

The above table outlines a theoretically possible daisy-chaining configuration for connecting multiple power supplies. However, it is essential that a qualified local electrician reviews, adapts, and verifies the installation to ensure full compliance with local electrical regulations and site-specific requirements.

To maintain the product's technical specifications and IP rating, and to ensure compliance with all safety regulations in the country of installation, this product must be installed exclusively by professionally trained personnel.

## CONNECTOR HANDLING & INSTALLATION SAFETY REQUIREMENTS

Correct handling of the connectors is essential to ensure long-term mechanical integrity and sealing performance. Installers must follow the installation and operating procedures exactly as described. Failure to comply can result in damage to the connector assembly and loss of sealing capability.

### Mandatory Handling Instructions:

- All plug connections must be inserted and removed **strictly along their main (longitudinal) axis**.
- **Do not bend, twist, or lever** the connectors during removal. Any extraction force applied perpendicularly to the connector's axis is strictly prohibited.
- If a connector appears difficult to disconnect, apply:
  - A **firmer actuation** of the release/clicking mechanism.
  - A **higher axial pull-out force**, without any lateral movement.

Bending a connector during disconnection can stress the internal threaded components, potentially loosening the nut or damaging the plastic threads. This leads to compromised sealing and mechanical reliability.

These requirements must be understood and strictly followed by all installation personnel.

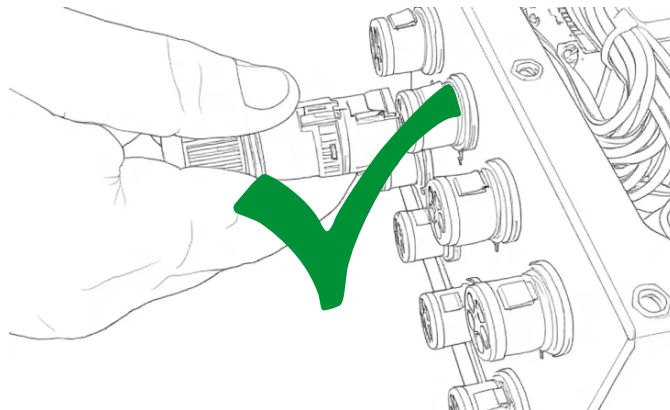

All plug connections must be inserted and removed **strictly along their main (longitudinal) axis**.

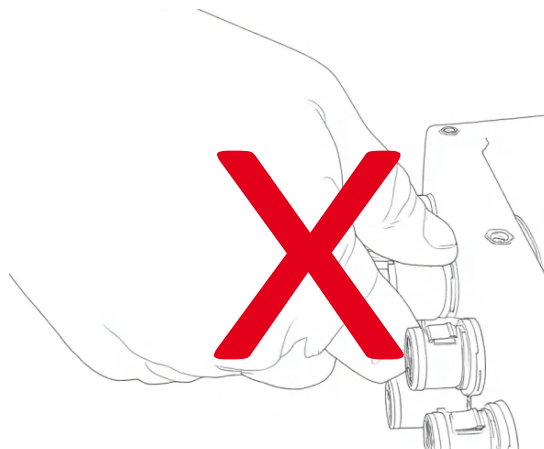

**Do not bend, twist, or lever** the connectors during removal.

## TEST & CERTIFICATION

Compliant with:

Remark:

Emission according to EN IEC 55015:2019 + A11:2020

Harmonics according to EN IEC 61000-3-2:2019 + A1:2021 + A2:2024

EN IEC 61000-3-2

EN 61000-4-7

Flicker according to EN IEC 61000-3-3:2013+ A1:2019 + A2:2021

EN 61000-4-15

Susceptibility according to EN IEC 61547:2023

EN 61000-4-2:2008/2009

EN 61000-4-3:2020

EN 61000-4-8:2009/2010

EN 61000-4-4:2012

EN 61000-4-6:2013/2014

EN 61000-4-5:2014/ A1:2017

EN 61000-4-11:2020

EN IEC 55015:2019 + A11:2020

CISPR 16-1-1:2015

Specification for radio disturbance and immunity measuring apparatus and methods - Part 1-1: Radio disturbance and immunity measuring apparatus – Measuring apparatus

CISPR 16-1-2:2014

Specification for radio disturbance and immunity measuring apparatus and methods - Part 1-2: Radio disturbance and immunity measuring apparatus – Ancillary equipment – Conducted disturbances EN 55016-1-2:2014

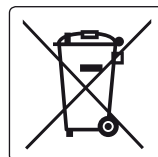

## TEST & CERTIFICATION

Compliant with:

Remark:

EN IEC 55015:2019 + A11:2020

CISPR 16-1-4:2010  
+A1:2012 + A2:2017

Specification for radio disturbance and immunity measuring apparatus and methods - Part 1-4: Radio disturbance and immunity measuring apparatus – Antennas and test sites for radiated disturbance measurements  
EN 55016-1-4:2010 + A1:2012 + A2:2017

CISPR 16-2-1:2014 + A1:2017

Specification for radio disturbance and immunity measuring apparatus and methods - Part 2-1: Methods of measurement of disturbances and immunity – Conducted disturbance measurements EN 55016+2+1:2014 + A1:2017

CISPR 16-2-3:2016

Specification for radio disturbance and immunity measuring apparatus and methods - Part 2-1: Methods of measurement of disturbances and immunity – Radiated disturbance measurements EN 55016-2-3:2017

CISPR 16-4-2:2011 + A1:2014

Specification for radio disturbance and immunity measuring apparatus and methods - Part 4-2: Uncertainties, statistics and limit modelling – Measurement instrumentation uncertainty EN 55016-4-2:2011 + A1:2014

CISPR 32:2015 + A1:2019

Electromagnetic compatibility of multimedia equipment – Emission requirements  
EN 55016-1-1:2015

CISPR 35:2016

Electromagnetic compatibility of multimedia equipment – Immunity requirements

EN IEC 61547:2023

IEC 61000-4-2:2008

Electromagnetic compatibility (EMC) – part 4-2: Testing and measurement techniques – Electrostatic discharge immunity test EN 61000-4-2:2009

IEC 61000-4-3:2006  
+A1:2007 + A2:2010

Electromagnetic compatibility (EMC) – part 4-3: Testing and measurement techniques – Radiated, radio-frequency, electromagnetic field immunity test  
EN 61000-4-3:2006 + A1:2008 + A2:2010

IEC 61000-4-4:2012

Electromagnetic compatibility (EMC) – part 4-4: Testing and measurement techniques – Electrical fast transients/burst immunity test EN 61000-4-4:2012



## TEST & CERTIFICATION

Compliant with:

Remark:

EN IEC 61547:2023

IEC 61000-4-5:2014 + A1:2017

Electromagnetic compatibility (EMC) – part 4-5: Testing and measurement techniques – Surge immunity test EN 61000-4-5:2014 + A1:2017

IEC 61000-4-6:2013

Electromagnetic compatibility (EMC) – part 4-6: Testing and measurement techniques – Immunity to conducted disturbances, induced by radio-frequency fields EN 61000-4-6:2014

IEC 61000-4-8:2009

Electromagnetic compatibility (EMC) – part 4-8: Testing and measurement techniques – Power frequency magnetic field immunity test EN 61000-4-8:2010

IEC 61000-4-11:2004 + A1:2017

Electromagnetic compatibility (EMC) – part 4-11: Testing and measurement techniques – Voltage dips, short interruptions and voltage variations immunity tests EN 61000-4-11:2004 + A1:2017

IEC CISPR 15:2018

Limits and methods of measurement of radio disturbance characteristics of electrical lighting and similar equipment EN IEC 55015:2019 + A1:2020

EN IEC 61547:2023

IEC 61000-4-7:2002 + A1:2008

Electromagnetic compatibility (EMC) – Part 4-7: Testing and measurement techniques – General guide on harmonics and interharmonics measurements and instrumentation, for power supply systems and equipment connected thereto EN 61000-4-7:2002 + A1:2009

EN 55032:2015 + A1:2020 + A11:2020

Electromagnetic compatibility of multimedia equipment - Emission requirements

EN 55035:2017 / A11:2020

Electromagnetic compatibility of multimedia equipment - Immunity requirements

EN IEC 61547:2023

Equipment for general lighting purposes - EMC immunity requirements

EN IEC 55015:2019 + A11:2020

Limits and methods of measurement of radio disturbance characteristics of electrical lighting and similar equipment



## TEST & CERTIFICATION

Compliant with:	Remark:
EN 63000:2019	Technical documentation for the assessment of electrical and electronic equipment regarding the restriction of hazardous substances (IEC 63000:2016)
EN 55035:2017 / A11:2020	Electromagnetic compatibility of multimedia equipment - Immunity requirements
EN IEC 61547:2023	Equipment for general lighting purposes - EMC immunity requirements
EN IEC 55015:2019 + A11:2020	Limits and methods of measurement of radio disturbance characteristics of electrical lighting and similar equipment
EN 61347-2:13	Particular requirements for electronic controlgear for LED light sources
EN IEC 61547:2023	Equipment for general lighting purposes - EMC immunity requirements
EN IEC 60598-1:2021	General safety requirements and tests
EN 61347-1:2021	Devices for lamps - Part 1: General and safety requirements (IEC 61347-1:2015 + A1:2017) Devices for lamps - Part 2: Particular requirements for electronic controlgear for LED modules



## INSTALLATION &amp; SAFETY INSTRUCTIONS



**Devices must be installed by qualified personnel in compliance with all pertaining regulations.**

- Before installation, please visit the product page at [www.x-led.de](http://www.x-led.de) to download the latest version of the installation instructions.
- Always refer to the technical parameters in the datasheet. All items are subject to technical modifications.
- Follow all safety instructions included in this manual to ensure correct powering of the device. Refer to the User Manual for proper usage guidelines.
- Consult the circuit diagram to ensure correct wiring.
- Important! Before performing any work, ensure the device is completely disconnected from the main power supply.
- High Voltage Warning! Before opening the device's protective case/lid or performing any work inside the device, disconnect power and wait 1 minute to discharge residual voltage.
- Ensure proper protection against electrical shock during installation.
- RCD circuit breakers (16A) are strongly recommended for added safety and fire hazard prevention.
- Flawless electrical connectivity must be ensured at all times.
- Do not install or remove LED-DOTs/LED-LINEs while the device is powered. Connecting LED-DOTs/LED-LINEs to a powered device may cause damage and will void the product warranty.
- Do not install the device in enclosed spaces without proper ventilation or air circulation.
- The ambient temperature must be between -25°C (-13°F) and 50°C (122°F).
- The equipment contains electrical and electronic components that must not come into contact with water, oil, or any other liquids, as this may compromise safety and reliability.
- Never install the equipment in areas where condensation may occur (avoid installation in high humidity environments).
- Do not install the device on flammable surfaces. Maintain a minimum safety distance of 0.1m (3.937") from flammable materials. Adjacent components must be temperature-resistant up to 90°C (194°F).
- Do not place heat insulation materials on the device.
- The device must be powered through a breaker/differential-switch-protected power line.
- Do not operate the power supply without proper grounding.
- Ensure the input voltage matches the specified range. Over-voltage or under-voltage may damage the power supply.
- Protect the device from stagnant water. Although the power supply is IP65-rated, it should not be submerged in water or exposed to heavy rainfall. It is protected against dust and water spray from all directions.
- Do not attempt installation in wet or extreme weather conditions.
- Do not leave or expose the device uncovered in wet, rainy, or snowy environments when not connected.
- Do not operate the device in an electric circuit shared with inductive consumers, such as: Fluorescent lamps, Gas discharge lamps, Ventilators. Activating inductive consumers in the same circuit may cause damage to the operating device.
- Do not modify the device in any way. No liability will be assumed for damage caused by alterations, improper use, or faulty installation.
- Ensure that the power cable does not come into contact with any other cables.
- Only authorized and trained personnel should operate the device. For technical assistance or service-related inquiries, please contact Carl Stahl ARC GmbH directly.
- IMPORTANT: Please ensure that the power supply is protected from direct sunlight to avoid overheating. Provide adequate ventilation and maintain both ambient and operating temperatures within the specified limits to guarantee optimal performance and extend the lifespan of the device.
- Ensure that the power supply is not accessible to unauthorized persons, especially in public or commercial spaces.

## DESICCANT BAG / DRY BAG



Every power supply contains a desiccant bag. We recommend to leave the bag inside of the power supply in case of unexpected condensation.

## WARRANTY

We provide a 5-year warranty for our power supply units (**XLED-PS-**) starting from the date of purchase. Any other system-related products (e.g. products from other manufacturers) are covered by their standard warranty terms.

For interior installations, a failure rate of up to 3% and for exterior installations, a failure rate of up to 5% may occur. Please note that these failure rates do not constitute a warranty claim.

Failures, damage, or consequential damage to the power supplies caused by improper installation, mounting, or handling are not covered under the warranty. Visual changes due to UV exposure, salt, or other environmental factors that do not affect the functional behavior of the product are not covered by the warranty. Damage resulting from exceeding the specified operating temperature limits is not covered. It is the responsibility of the client to ensure that the operating temperature stays within the recommended range.

We advise ordering a sufficient quantity of spare parts for future needs. For professional replacement and installation, we offer training by our specialists. Compliance with our installation and maintenance guidelines is a requirement for this warranty to be valid.

Issues arising due to site and application conditions that are not specifically addressed, will not be covered by the warranty unless the client has informed us of these conditions in advance. Installation must be performed by trained and qualified personnel to ensure the warranty is valid.

For all other conditions and claims, our General Sales and Planning Terms apply. These terms are available for download on our website.

## INSTALLING, SECURING THE DEVICE AND SAFETY INSTRUCTIONS

Ensure that the device is safely installed and securely fastened to prevent any mechanical hazards, ensure safe operation, and allow access for maintenance purposes. This equipment must not be left hanging or freely suspended; it must be firmly mounted onto a rigid surface using the four provided mounting holes, each with a diameter of 6 mm.

To ensure the safe and reliable operation of both the LED-DOTs and our power supply, it is crucial to install surge protection devices to safeguard both the branch circuit and the connected equipment. Always adhere to local electrical codes.

Ensure that protective measures are in place to address:

1. Short Circuiting
2. Electrical Overloading
3. Over-Heating due to excessive operating voltage

## MAINTENANCE

Proper maintenance is essential for the reliable operation of the power supply units. We recommend regular inspections and cleaning of the equipment, particularly for outdoor installations exposed to environmental factors such as dust, UV, or moisture. Use solvent-free cleaning agents only and do not employ aggressive chemicals or high pressure cleaner. Periodic checks should include verifying connections, ensuring proper ventilation, and confirming that the operating temperature is within specified limits. Failure to follow these maintenance guidelines may void the warranty.

## SERVICE CONDITIONS

Service and repair requests must be accompanied by proof of purchase and a detailed description of the issue. Service is only available if the product (e.g. LED-Line, power supply) has been installed, operated, and maintained in accordance with our guidelines. Any modification or unauthorized repair of the product will void the warranty.

## SERVICE AND SUPPORT

If any issues arise with one of our products, customers can contact our service department for support. Our team will assist with troubleshooting and, if necessary, arrange for repairs or replacements in line with the warranty terms. We provide technical support via phone, email, or online chat. For more complex service needs, our trained technicians are available for on-site support, subject to additional charges. Service requests can be submitted through our website or directly to our customer support team.

## CONTACT



Carl Stahl ARC GmbH  
Siemensstrasse 2  
73079 Suessen  
GERMANY

Phone: +49 (0) 7162/948 150 300 | Fax: +49 (0) 7162/948 150 305  
E-Mail: [x-led@carlstahl-arc.com](mailto:x-led@carlstahl-arc.com)

### **COPYRIGHT:**

© Carl Stahl ARC GmbH. All rights reserved.

Specifications are subject to change without notice.

No representation or warranty as to the accuracy or completeness of the information included herein is given and any liability for any action in reliance thereon is disclaimed. All trademarks are owned by Carl Stahl ARC GmbH or their respective owners.

In the interest of continuous product improvement, we reserve the right to change specifications, setup and maintenance instructions, or product functionality at any time and without prior notice.

## ENVIRONMENTAL SAFETY AND WASTE DISPOSAL



This device must be disposed of at a suitable, legally regulated disposal center that allows for the recycling of electrical and electronic equipment, components, and materials once it reaches its end of life (EOL). Proper disposal in accordance with environmental safety regulations and modern waste management procedures significantly reduces the negative impact of these materials on the environment and public health while ensuring the correct recycling, reuse, and redistribution of key components.

Unlawful disposal of this device and its materials is strictly prohibited. Any inadequate or illegal disposal practices may result in administrative sanctions or penalties, as per the applicable laws and regulations in your country.

# Carl Stahl

ARCHITEKTUR

CARL STAHL ARC GMBH  
Siemensstraße 2  
D-73079 Süssen

Fon +49 (0) 7162 / 948 150 300  
Fax +49 (0) 7162 / 948 150 305

[x-led@carlstahl-arc.com](mailto:x-led@carlstahl-arc.com)  
[www.x-led.de](http://www.x-led.de)